

Horizontal  
flow pack

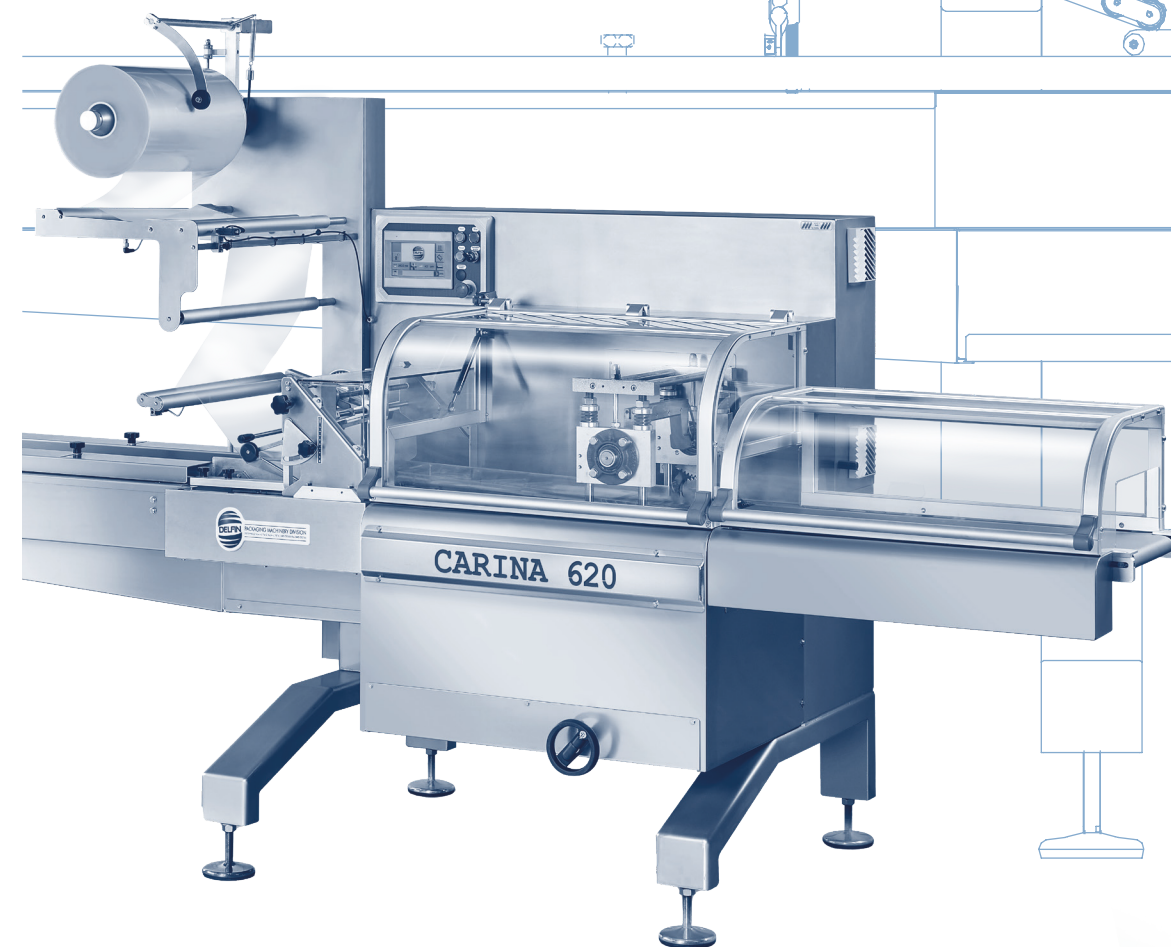

# CARINA 620

MADE IN ITALY

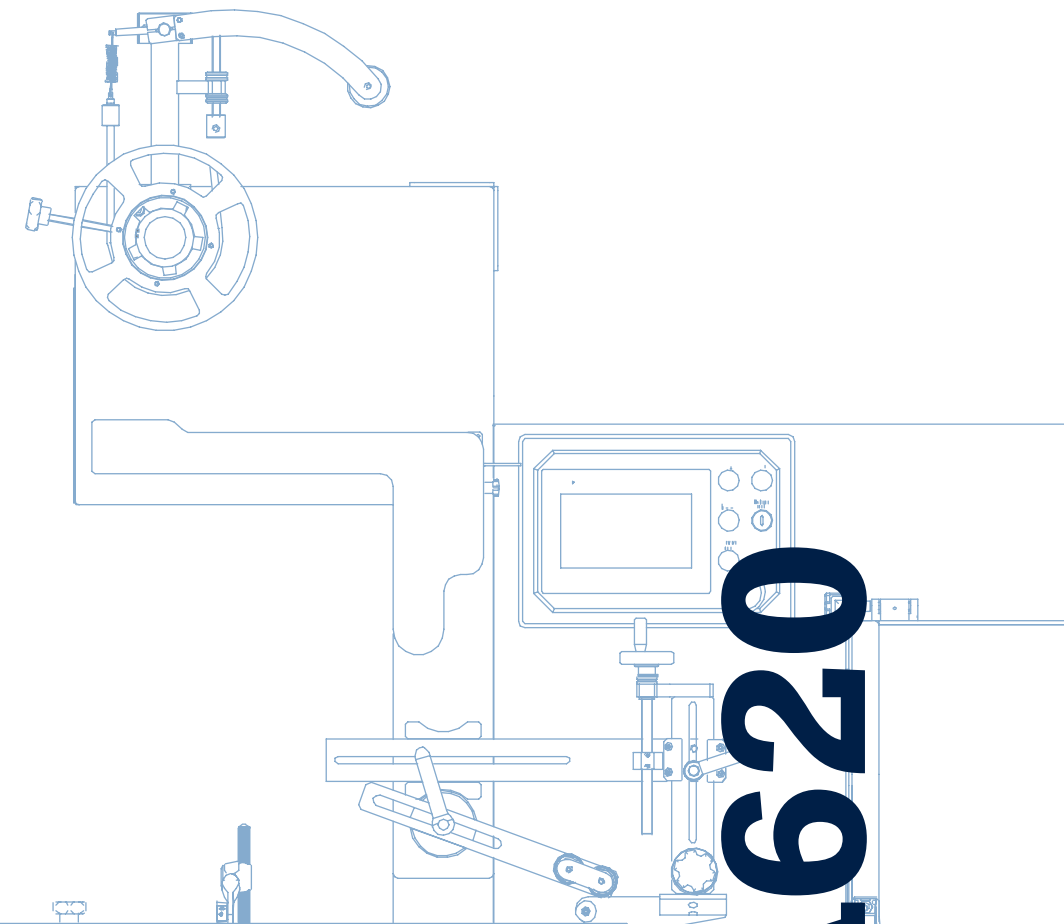

**Delfin srl**  
Via G. Keplero, 18  
36034 Malo, VI - Italy

+39 0445 58 06 88  
info@delfin.it  
www.delfin.it





# Flow pack CARINA 620

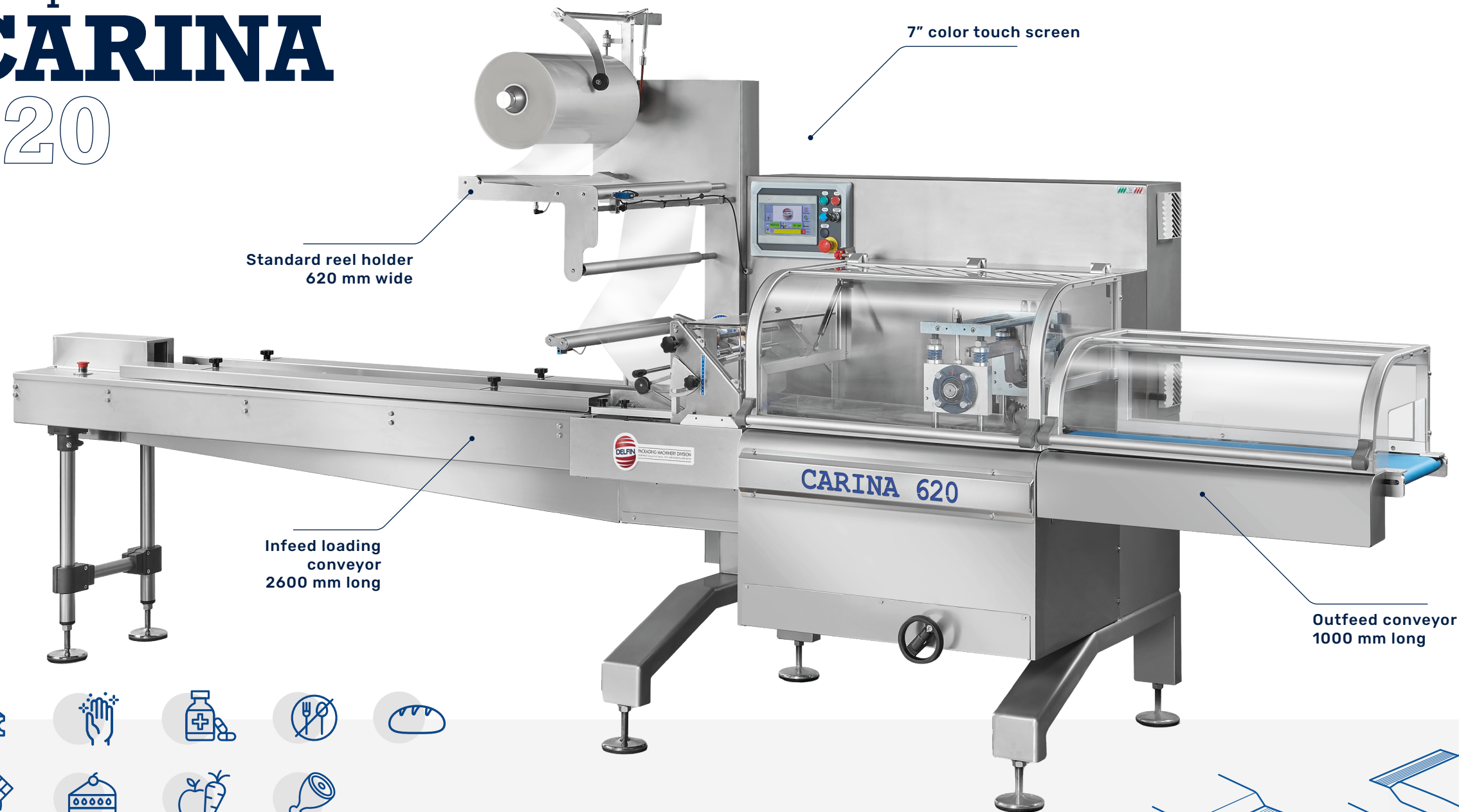

Standard reel holder  
620 mm wide

7" color touch screen

Infeed loading  
conveyor  
2600 mm long

Outfeed conveyor  
1000 mm long

- RAL 9006 grey painted steel frame with AISI 304 stainless steel guards;
- Longitudinal sealing unit consisting of three pairs of wheels: pulling, welding and folding flap. Pneumatic opening of sealing wheels;
- Rotary transversal sealing unit with one or multiple 300 mm wide up jaws;
- One self-centring reel holder;
- Adjustable or fixed forming box;
- Photocell for printed film;
- Photocell for "No Product - No Bag";
- Standard spare parts kit;
- Safety guards in transparent shockproof plastic material.

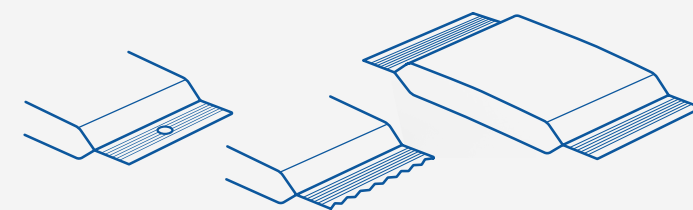

← Type of packaging

<b>Product length</b>	min 50 mm	max 600 mm
<b>Product width</b>	min 10 mm	max 220 mm
<b>Product height</b>	min 1 mm	max 120 mm
<b>Reel holder width</b>	620 mm on demand 720 mm	
<b>Mechanical speed</b>	max 200	
<b>Weight</b>	610 kg	
<b>Power supply</b>	4 Kw	

- Motorization by means of 3 independent Brushless motors
- Mechanical speed 200 rpm
- Voltage 400V / 3 phase Earth + Neutral, 50Hz
- Machine conforms to CE regulations

